

AIRTREND Ltd. - KOVENT D.O.O.

Kumanovska 14

11000 Beograd

Tel. 011 383 68 86, 308 57 40

Faks 011 344 41 13

E-mail: gobrid@eunet.rs, office@kovent.rs

www.airtrend.rs, www.kovent.rs

FläktGroup

WOODS | Air Movement

ROOF UNITS HIGH TEMPERATURE (HT)



ROOF UNITS – HIGH TEMPERATURE (HT)

CONTENTS

OVERVIEW	3
PRODUCT TECHNICAL INFORMATION	4-26
WIRING DIAGRAMS	27
ACCESSORIES	28-29



PRODUCT FACTS

- Volume flows up to 11 m³/s
- Static Pressures up to 850 Pa
- Both 1 Ph and 3 Ph available
- Available both in 50Hz and 60Hz (on request)
- Low sound level
- High efficiency
- Speed controllable
- ErP 2018 compliant [as per (UE)N 327/2011]
- Bird Guard and rain cowl included as standard

ELECTRICAL SUPPLY

- 220-240V / 50Hz / 1Φ & 380-420V / 50Hz / 3Φ

TEMPERATURE RANGE

- Maximum continuous operation temperature: 110°C
- Maximum fire rated temperature: 400°C for 2 hours (as per EN 12101-3)

SIZES

- 225, 250, 280, 315, 355, 400, 450, 500, 560, 630, 710, 800, 900 and 1000 mm

CONSTRUCTION

The roof cowl is made of seawater-resistant aluminum. The structure, roof base support and bird protection guard are made up of galvanized steel.

MOTOR

Standard asynchronous motor with IP 55 protection and Class F insulation.

IMPELLER

The centrifugal impeller has high efficiency backward curved blades and is manufactured of steel with self-cleaning system.

INSTALLATION

Fans can be mounted on flat roofs and tilted ($\leq 45^\circ$) roofs via either installation frames or alternatively can be fitted directly to the roof base. Fans are suitable for smoke extraction, smoke emergency exhaust with motor outside the hazardous area, for air renewal in buildings, industries and professional kitchen hoods.

Note: All Sound Pressure values provided are measured at 1.5 m from the source in free-field conditions.

SPEED CONTROLLERS

The fans are available with speed controls and can be controlled using a separate transformer speed control or electronic controllers for the 1 phase fans and with frequency controllers for 3 phase fans. It is advised to use sinusoidal filters between the inverter and the motor which are effective for all phases as offered by manufacturers. The speed controllers should be selected, ordered and supplied separately.

PRODUCT CODE

HTC-123-4-5 6

- HTC – HT roof fan
- 123 – Impeller Diameter e.g., 250
- 4 – Pole Speed, e.g., 2/4/6
- 5 – Electrical Phase, e.g., 1/3
- 6 – Motor rated power in kW

ACCESSORIES - CONTROLLERS

The range of accessories include manual and gravity shutters, swing-out frame, vertical discharge socket, flexible connectors and insulating connections



Shutters



Swing-out



Vertical discharge socket



Safety switch



PERFORMANCE CHART

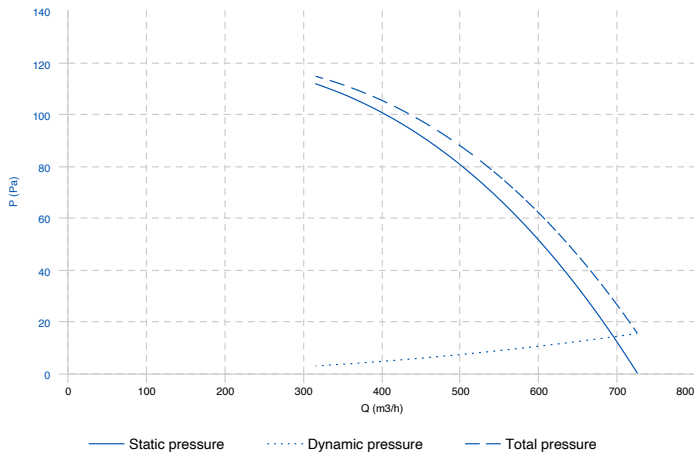

Model Name	Part Code	Motor Nominal data at 50Hz supply voltage	Power (kW)	Max Current (A)	Max. Airflow (m³/h)	Speed (rpm)	IP Class
HTC-225-4-1-0.12	CH225415	220-240V/50Hz/1pH	0.12	1.15	730	1380	IP55

Model Name	Sound Path	Lw Spectrum [dB(A)]								
		63	125	250	500	1000	2000	4000	8000	Total
HTC-225-4-1-0.12	Inlet	40	48	53	56	57	55	52	47	62

Fan Size	A	B	C	D	E	F	G	H	I	K	Weight (kg)
HTC-225-4-1-0.12	463	442	435	330	9	203	112.25	30	20.75	278.9	9

DRAWINGS AND DIMENSIONS

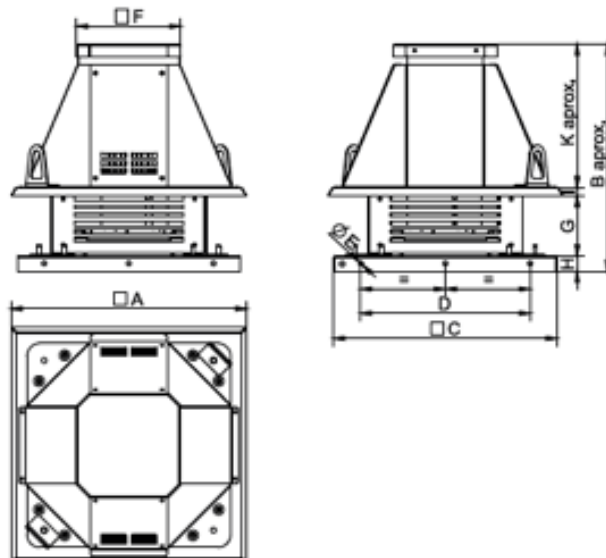

PERFORMANCE CHART

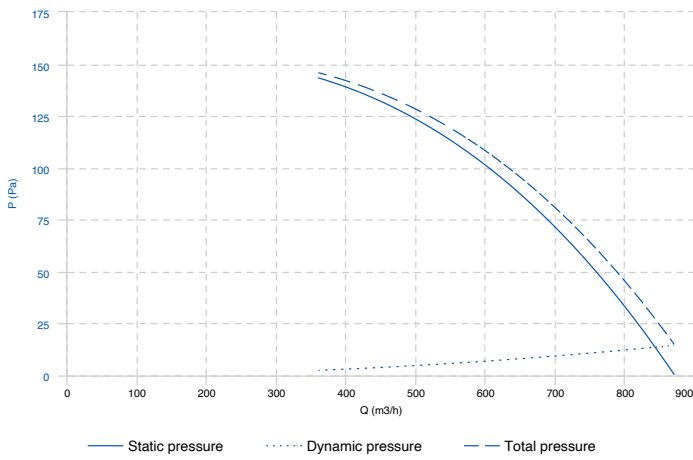

Model Name	Part Code	Motor Nominal data at 50Hz supply voltage	Power (kW)	Max Current (A)	Max. Airflow (m³/h)	Speed (rpm)	IP Class
HTC-250-4-1-0.12	CH250415	220-240V/50Hz/1pH	0.12	1.15	870	1380	IP55

Model Name	Sound Path	Lw Spectrum [dB(A)]								
		63	125	250	500	1000	2000	4000	8000	Total
HTC-250-4-1-0.12	Inlet	43	51	55	59	60	58	55	50	65

Fan Size	A	B	C	D	E	F	G	H	I	K	Weight (kg)
HTC-250-4-1-0.12	463	442	435	330	9	203	112.25	30	20.75	278.9	10

DRAWINGS AND DIMENSIONS

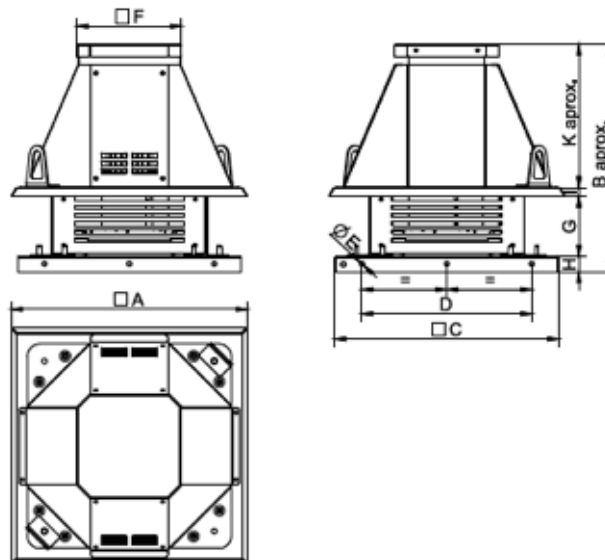

PERFORMANCE CHART

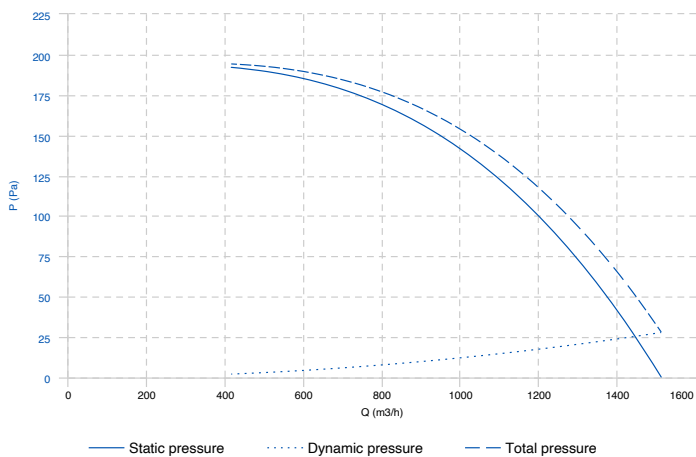

Model Name	Part Code	Motor Nominal data at 50Hz supply voltage	Power (kW)	Max Current (A)	Max. Airflow (m³/h)	Speed (rpm)	IP Class
HTC-280-4-1-0.12	CH280415	220-240V/50Hz/1pH	0.12	1.15	1510	1380	IP55

Model Name	Sound Path	Lw Spectrum [dB(A)]								
		63	125	250	500	1000	2000	4000	8000	Total
HTC-280-4-1-0.12	Inlet	48	56	60	63	65	63	60	55	70

Fan Size	A	B	C	D	E	F	G	H	I	K	Weight (kg)
HTC-280-4-1-0.12	583	500	595	450	9	203	140.75	40	20.75	298.5	11

DRAWINGS AND DIMENSIONS

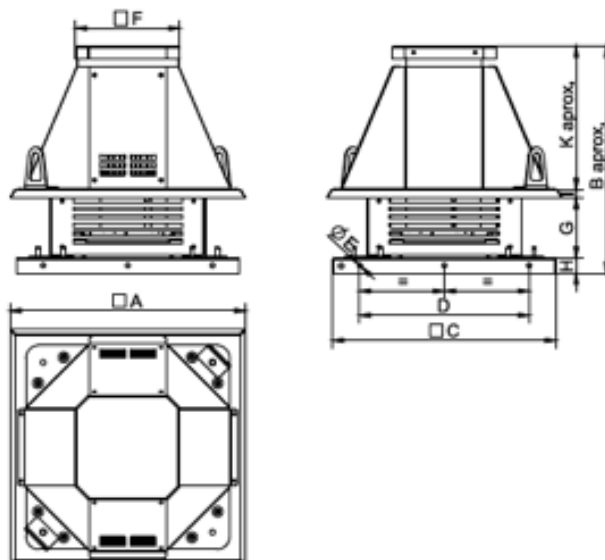

PERFORMANCE CHART

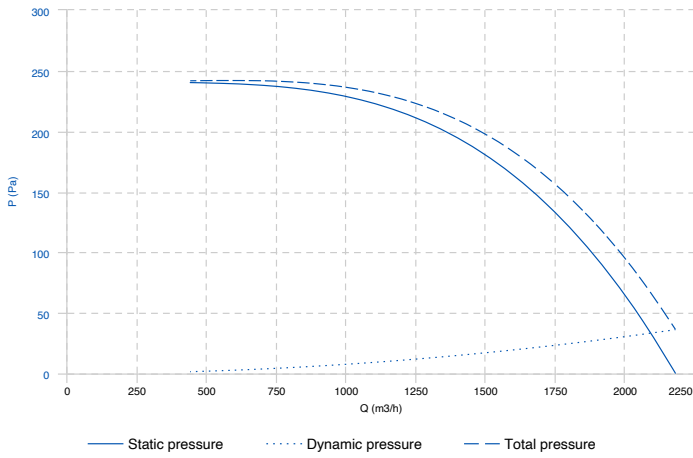

Model Name	Part Code	Motor Nominal data at 50Hz supply voltage	Power (kW)	Max Current (A)	Max. Airflow (m³/h)	Speed (rpm)	IP Class
HTC-315-4-1-0.25	CH315415	220-240V/50Hz/1pH	0.25	1.93	2180	1400	IP55

Model Name	Sound Path	Lw Spectrum [dB(A)]								
		63	125	250	500	1000	2000	4000	8000	Total
HTC-315-4-1-0.25	Inlet	52	60	64	68	69	67	64	59	74

Fan Size	A	B	C	D	E	F	G	H	I	K	Weight (kg)
HTC-315-4-1-0.25	583	544.6	595	450	9	203	185.25	40	20.75	298.5	15

DRAWINGS AND DIMENSIONS

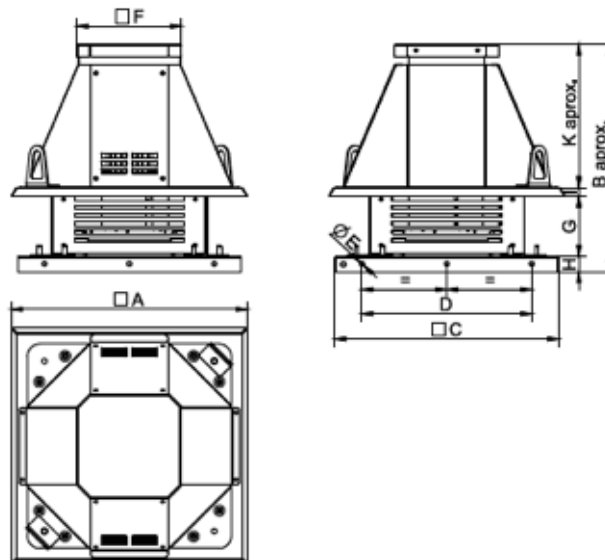

PERFORMANCE CHART

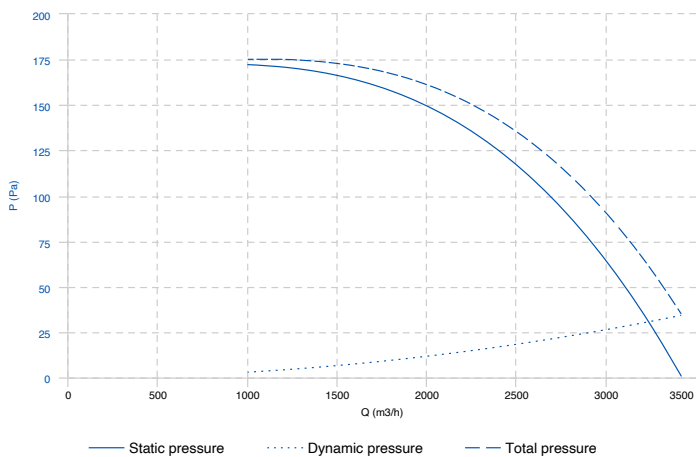

Model Name	Part Code	Motor Nominal data at 50Hz supply voltage	Power (kW)	Max Current (A)	Max. Airflow (m³/h)	Speed (rpm)	IP Class
HTC-400-6-1-0.37	CH400615	220-240V/50Hz/1pH	0.37	2.9	3420	890	IP55

Model Name	Sound Path	Lw Spectrum [dB(A)]								
		63	125	250	500	1000	2000	4000	8000	Total
HTC-400-6-1-0.37	Inlet	51	59	63	67	68	66	63	58	73

Fan Size	A	B	C	D	E	F	G	H	I	K	Weight (kg)
HTC-400-6-1-0.37	664.4	702.75	665	520	9	253	268.75	40	30.75	363.25	21

DRAWINGS AND DIMENSIONS

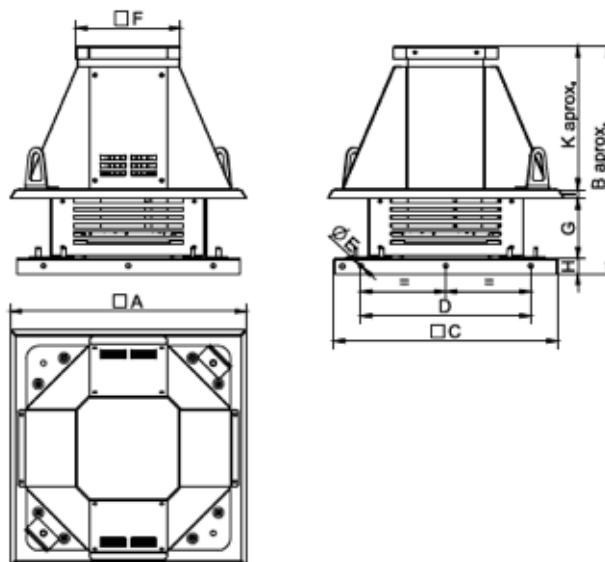

PERFORMANCE CHART

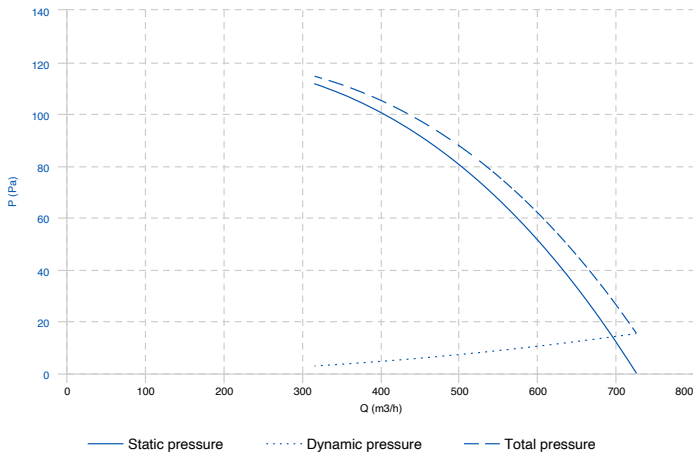

Model Name	Part Code	Motor Nominal data at 50Hz supply voltage	Power (kW)	Max Current (A)	Max. Airflow (m³/h)	Speed (rpm)	IP Class
HTC-225-4-3-0.12	CH225435	380-420V/50Hz/3pH	0.12	0.46	730	1400	IP55

Model Name	Sound Path	Lw Spectrum [dB(A)]								
		63	125	250	500	1000	2000	4000	8000	Total
HTC-225-4-3-0.12	Inlet	40	48	53	56	57	55	52	47	62

Fan Size	A	B	C	D	E	F	G	H	I	K	Weight (kg)
HTC-225-4-3-0.12	463	442	435	330	9	203	112.25	30	20.75	278.9	9

DRAWINGS AND DIMENSIONS

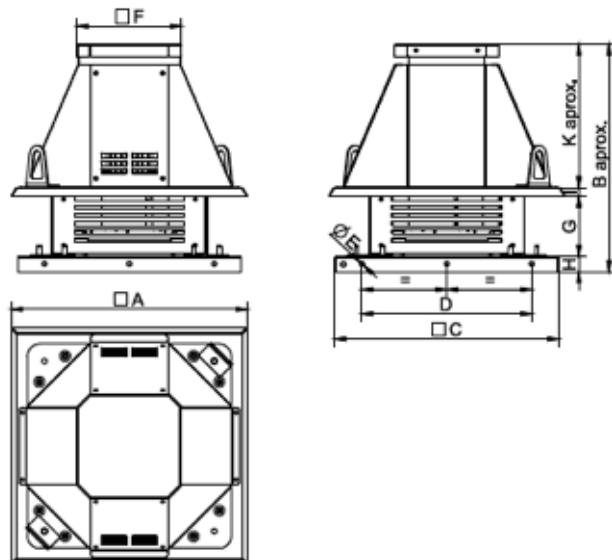

INVERTER DETAILS

Part Number	Description
EA901016	IDDXF-54-2.2



PERFORMANCE CHART

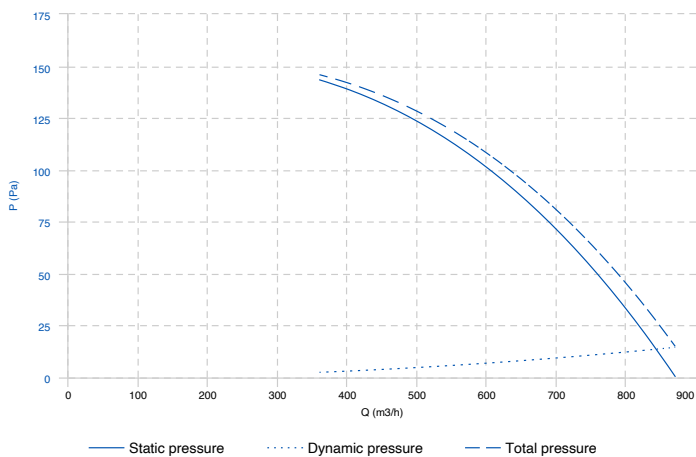

Model Name	Part Code	Motor Nominal data at 50Hz supply voltage	Power (kW)	Max Current (A)	Max. Airflow (m³/h)	Speed (rpm)	IP Class
HTC-250-4-3-0.12	CH250435	380-420V/50Hz/3pH	0.12	0.46	870	1400	IP55

Model Name	Sound Path	Lw Spectrum [dB(A)]								
		63	125	250	500	1000	2000	4000	8000	Total
HTC-250-4-3-0.12	Inlet	43	51	55	59	60	58	55	50	65

Fan Size	A	B	C	D	E	F	G	H	I	K	Weight (kg)
HTC-250-4-3-0.12	463	442	435	330	9	203	112.25	30	20.75	278.9	10

DRAWINGS AND DIMENSIONS

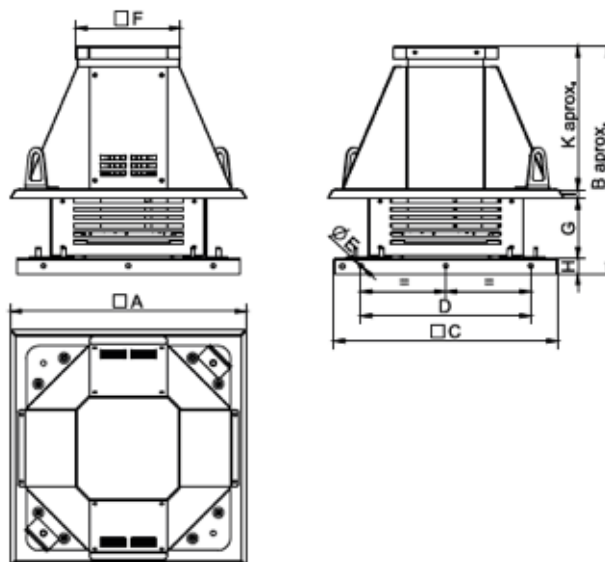

INVERTER DETAILS

Part Number	Description
EA901016	IDDXF-54-2.2



PERFORMANCE CHART

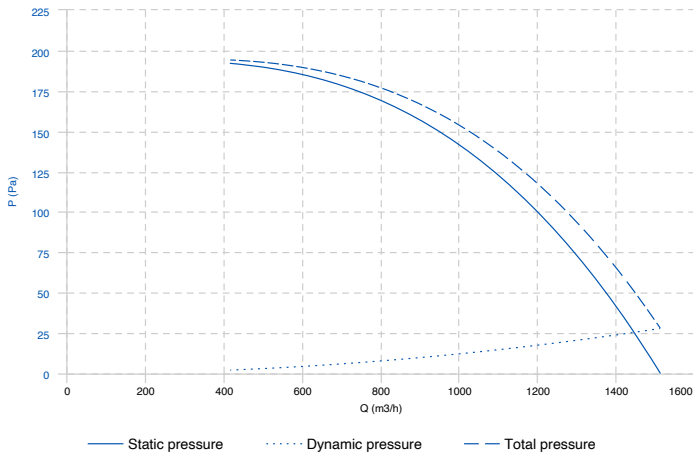

Model Name	Part Code	Motor Nominal data at 50Hz supply voltage	Power (kW)	Max Current (A)	Max. Airflow (m³/h)	Speed (rpm)	IP Class
HTC-280-4-3-0.12	CH280435	380-420V/50Hz/3pH	0.12	0.46	1510	1400	IP55

Model Name	Sound Path	Lw Spectrum [dB(A)]								
		63	125	250	500	1000	2000	4000	8000	Total
HTC-280-4-3-0.12	Inlet	48	56	60	63	65	63	60	55	70

Fan Size	A	B	C	D	E	F	G	H	I	K	Weight (kg)
HTC-280-4-3-0.12	583	500	595	450	9	203	140.75	40	20.75	298.5	11

DRAWINGS AND DIMENSIONS

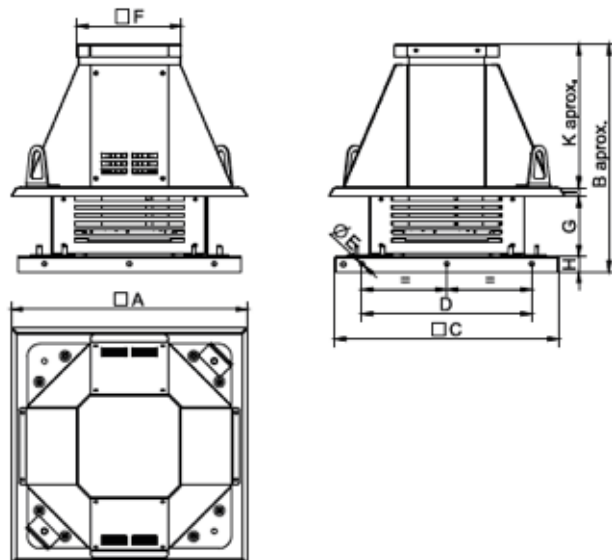

INVERTER DETAILS

Part Number	Description
EA901016	IDDXF-54-2.2



PERFORMANCE CHART

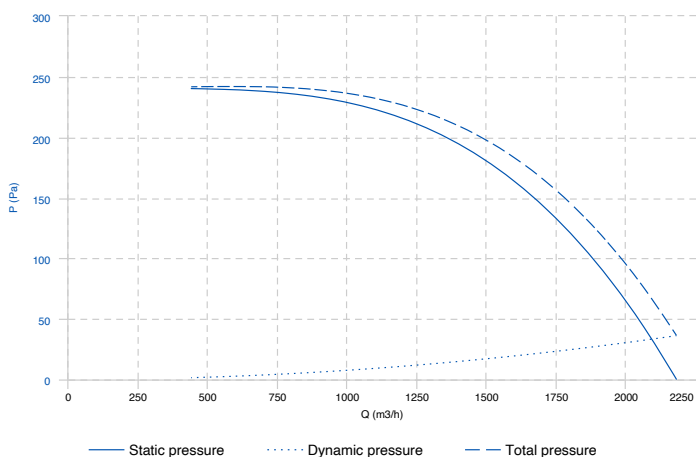

Model Name	Part Code	Motor Nominal data at 50Hz supply voltage	Power (kW)	Max Current (A)	Max. Airflow (m³/h)	Speed (rpm)	IP Class
HTC-315-4-3-0.25	CH315435	380-420V/50Hz/3pH	0.25	0.79	2180	1400	IP55

Model Name	Sound Path	Lw Spectrum [dB(A)]								
		63	125	250	500	1000	2000	4000	8000	Total
HTC-315-4-3-0.25	Inlet	52	60	64	68	69	67	64	59	74

Fan Size	A	B	C	D	E	F	G	H	I	K	Weight (kg)
HTC-315-4-3-0.25	583	544.6	595	450	9	203	185.25	40	20.75	298.5	15

DRAWINGS AND DIMENSIONS

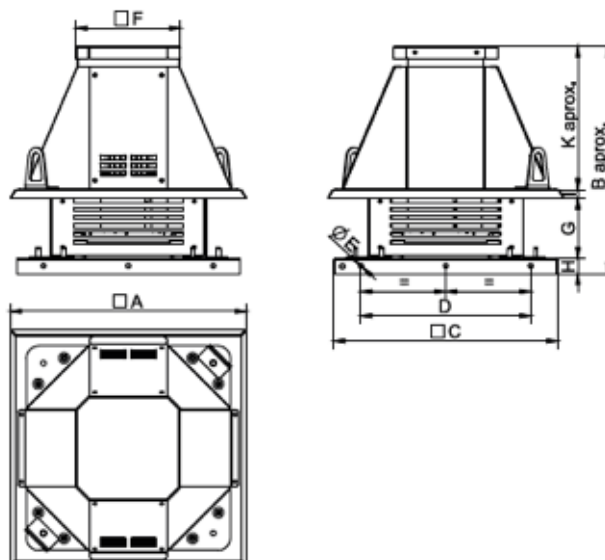

INVERTER DETAILS

Part Number	Description
EA901016	IDDXF-54-2.2



PERFORMANCE CHART

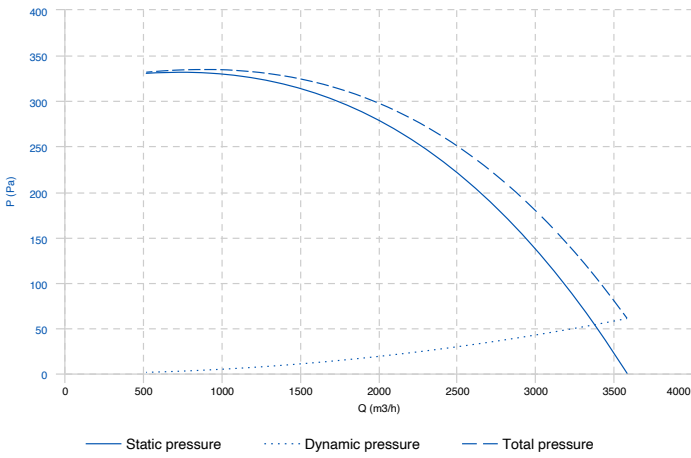

Model Name	Part Code	Motor Nominal data at 50Hz supply voltage	Power (kW)	Max Current (A)	Max. Airflow (m³/h)	Speed (rpm)	IP Class
HTC-355-4-3-0.55	CH355435	380-420V/50Hz/3pH	0.55	1.49	3590	1400	IP55

Model Name	Sound Path	Lw Spectrum [dB(A)]								
		63	125	250	500	1000	2000	4000	8000	Total
HTC-355-4-3-0.55	Inlet	56	64	68	72	73	71	68	63	78

Fan Size	A	B	C	D	E	F	G	H	I	K	Weight (kg)
HTC-355-4-3-0.55	664.6	644.6	665	520	9	253	210.8	40	30.75	363.25	19

DRAWINGS AND DIMENSIONS

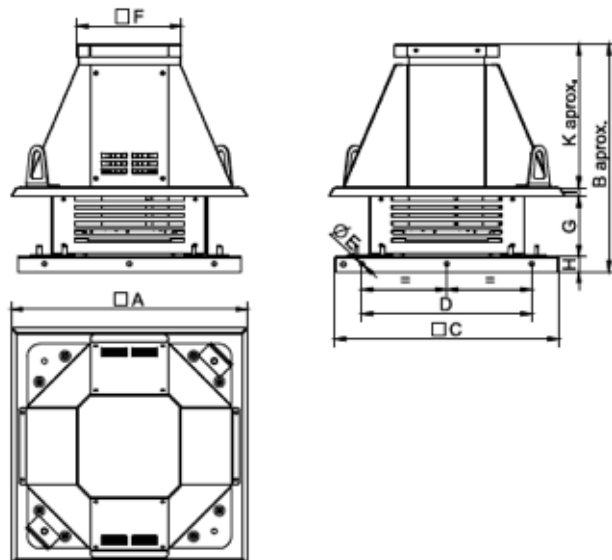

INVERTER DETAILS

Part Number	Description
EA901016	IDDXF-54-2.2



HTC-400-4-3-0.75

PERFORMANCE CHART

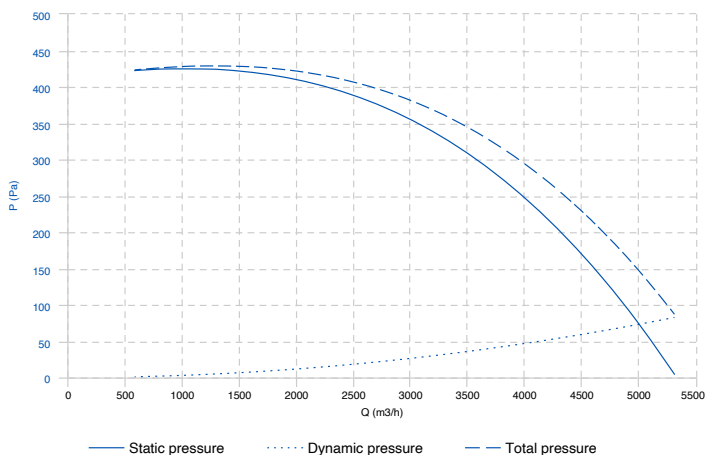

Model Name	Part Code	Motor Nominal data at 50Hz supply voltage	Power (kW)	Max Current (A)	Max. Airflow (m³/h)	Speed (rpm)	IP Class
HTC-400-4-3-0.75	CH400435	380-420V/50Hz/3pH	0.75	1.63	5310	1390	IP55

Model Name	Sound Path	Lw Spectrum [dB(A)]								
		63	125	250	500	1000	2000	4000	8000	Total
HTC-400-4-3-0.75	Inlet	60	68	72	76	77	75	72	67	82

Fan Size	A	B	C	D	E	F	G	H	I	K	Weight (kg)
HTC-400-4-3-0.75	664.4	702.75	665	520	9	253	268.75	40	30.75	363.25	21

DRAWINGS AND DIMENSIONS

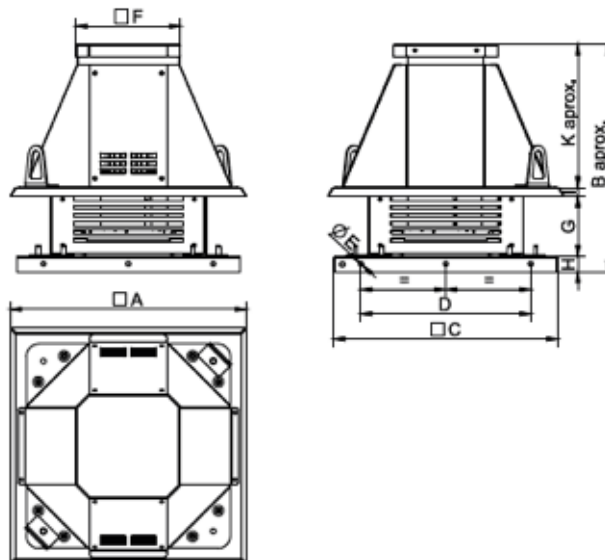

INVERTER DETAILS

Part Number	Description
EA901016	IDDXF-54-2.2



PERFORMANCE CHART

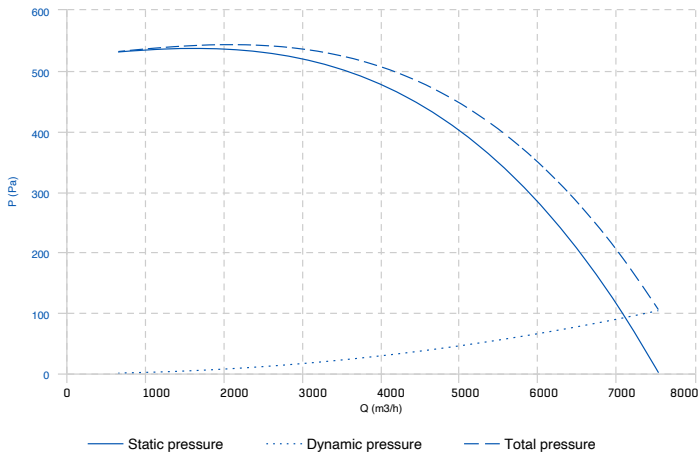

Model Name	Part Code	Motor Nominal data at 50Hz supply voltage	Power (kW)	Max Current (A)	Max. Airflow (m³/h)	Speed (rpm)	IP Class
HTC-450-4-3-1.1	CH450435	380-420V/50Hz/3pH	1.1	2.49	7530	1400	IP55

Model Name	Sound Path	Lw Spectrum [dB(A)]								
		63	125	250	500	1000	2000	4000	8000	Total
HTC-450-4-3-1.1	Inlet	64	72	76	79	81	79	76	71	86

Fan Size	A	B	C	D	E	F	G	H	I	K	Weight (kg)
HTC-450-4-3-1.1	774.6	758.15	665	520	9	253	304.25	40	30.75	383.15	38

DRAWINGS AND DIMENSIONS

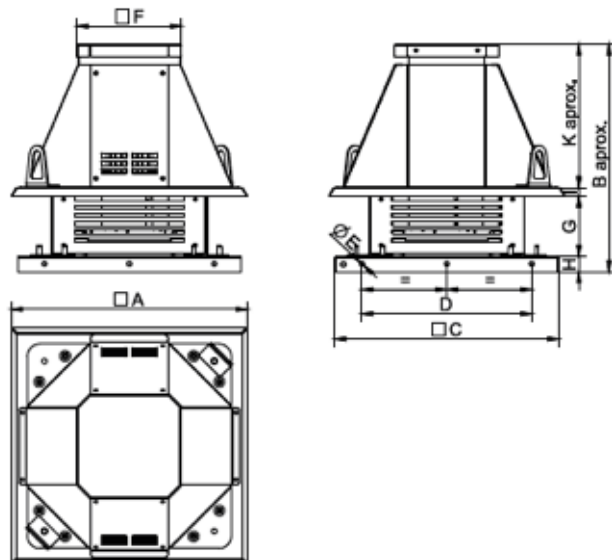

INVERTER DETAILS

Part Number	Description
EA901017	IDDXF-54-3.7



HTC-500-4-3-1.5

PERFORMANCE CHART

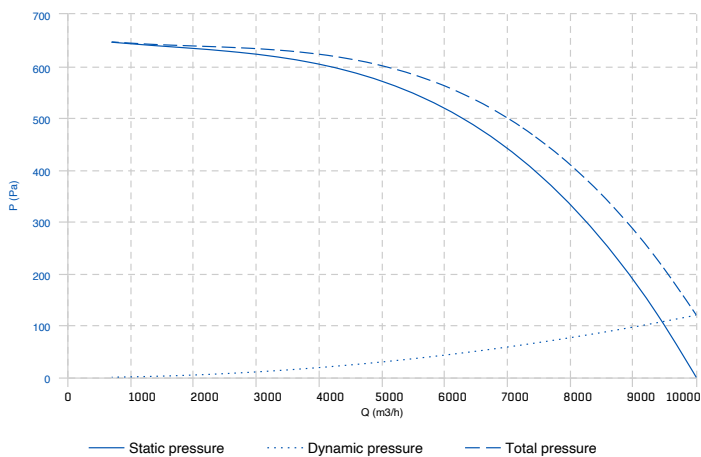

Model Name	Part Code	Motor Nominal data at 50Hz supply voltage	Power (kW)	Max Current (A)	Max. Airflow (m³/h)	Speed (rpm)	IP Class
HTC-500-4-3-1.5	CH500435	380-420V/50Hz/3pH	1.5	3.26	10000	1400	IP55

Model Name	Sound Path	Lw Spectrum [dB(A)]								
		63	125	250	500	1000	2000	4000	8000	Total
HTC-500-4-3-1.5	Inlet	66	74	79	82	83	82	78	73	89

Fan Size	A	B	C	D	E	F	G	H	I	K	Weight (kg)
HTC-500-4-3-1.5	939.6	863.65	939	710	9	353	319.5	50	31	463.15	50

DRAWINGS AND DIMENSIONS

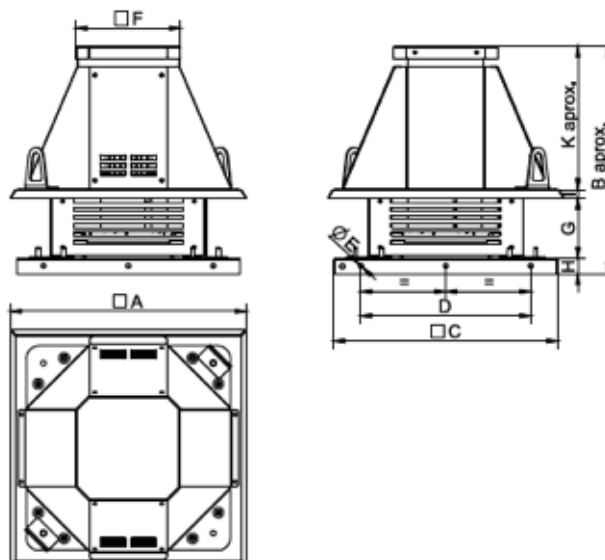

INVERTER DETAILS

Part Number	Description
EA901017	IDDXF-54-3.7



PERFORMANCE CHART

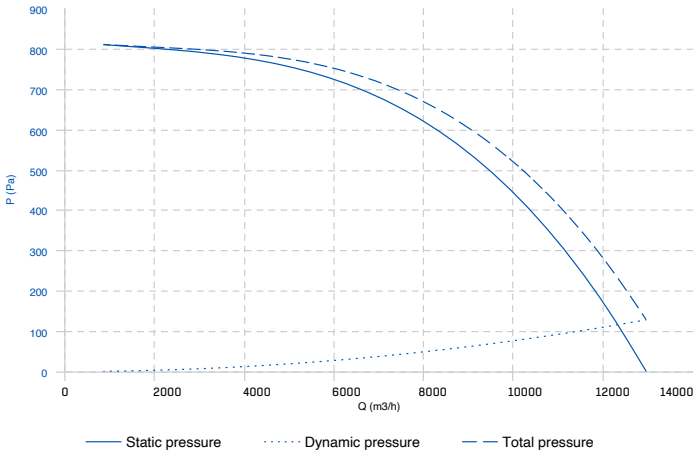

Model Name	Part Code	Motor Nominal data at 50Hz supply voltage	Power (kW)	Max Current (A)	Max. Airflow (m³/h)	Speed (rpm)	IP Class
HTC-560-4-3-3	CH560435	380-420V/50Hz/3pH	3	6.17	12950	1430	IP55

Model Name	Sound Path	Lw Spectrum [dB(A)]								
		63	125	250	500	1000	2000	4000	8000	Total
HTC-560-4-3-3	Inlet	69	77	82	85	86	84	81	76	91

Fan Size	A	B	C	D	E	F	G	H	I	K	Weight (kg)
HTC-560-4-3-3	939.6	863.65	939	710	9	353	319.5	50	31	463.15	55

DRAWINGS AND DIMENSIONS

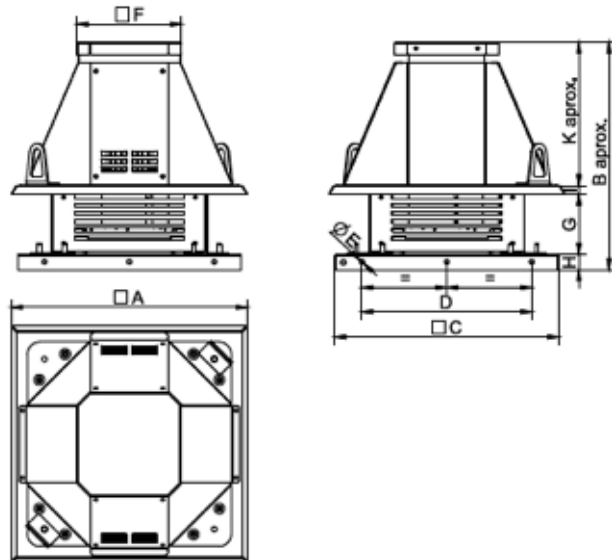

INVERTER DETAILS

Part Number	Description
EA901019	IDDXF-54-7.2



PERFORMANCE CHART

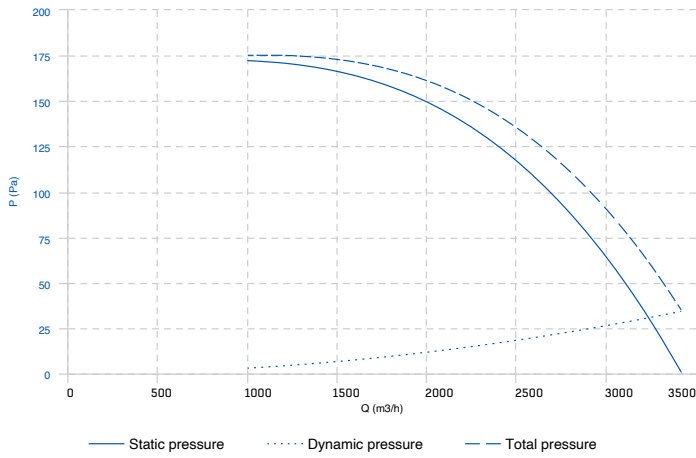

Model Name	Part Code	Motor Nominal data at 50Hz supply voltage	Power (kW)	Max Current (A)	Max. Airflow (m³/h)	Speed (rpm)	IP Class
HTC-400-6-3-0.37	CH400635	380-420V/50Hz/3pH	0.37	1.27	3420	900	IP55

Model Name	Sound Path	Lw Spectrum [dB(A)]								
		63	125	250	500	1000	2000	4000	8000	Total
HTC-400-6-3-0.37	Inlet	51	59	63	67	68	66	63	58	73

Fan Size	A	B	C	D	E	F	G	H	I	K	Weight (kg)
HTC-400-6-3-0.37	664.4	702.75	665	520	9	253	268.75	40	30.75	363.25	21

DRAWINGS AND DIMENSIONS

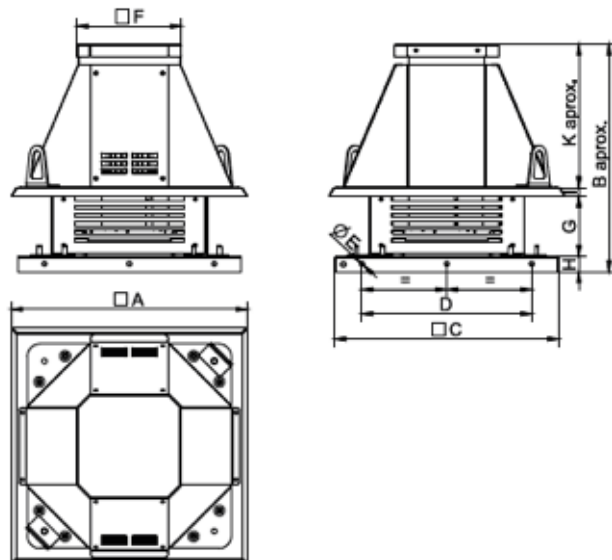

INVERTER DETAILS

Part Number	Description
EA901016	IDDXF-54-2.2



PERFORMANCE CHART

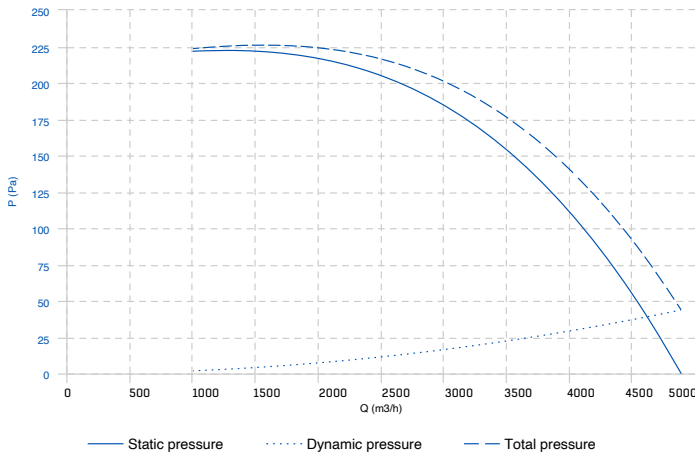

Model Name	Part Code	Motor Nominal data at 50Hz supply voltage	Power (kW)	Max Current (A)	Max. Airflow (m³/h)	Speed (rpm)	IP Class
HTC-450-6-3-0.37	CH450635	380-420V/50Hz/3pH	0.37	1.27	4890	910	IP55

Model Name	Sound Path	Lw Spectrum [dB(A)]								
		63	125	250	500	1000	2000	4000	8000	Total
HTC-450-6-3-0.37	Inlet	54	62	67	70	71	70	66	61	77

Fan Size	A	B	C	D	E	F	G	H	I	K	Weight (kg)
HTC-450-6-3-0.37	774.6	758.15	665	520	9	253	304.25	40	30.75	383.15	38

DRAWINGS AND DIMENSIONS

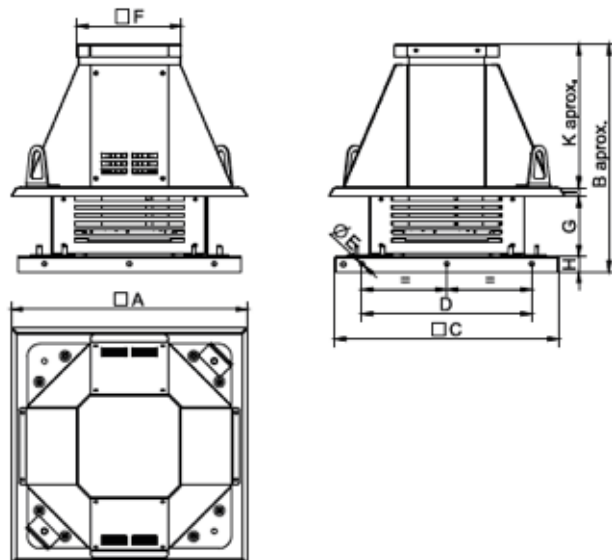

INVERTER DETAILS

Part Number	Description
EA901016	IDDXF-54-2.2



HTC-500-6-3-0.75

PERFORMANCE CHART

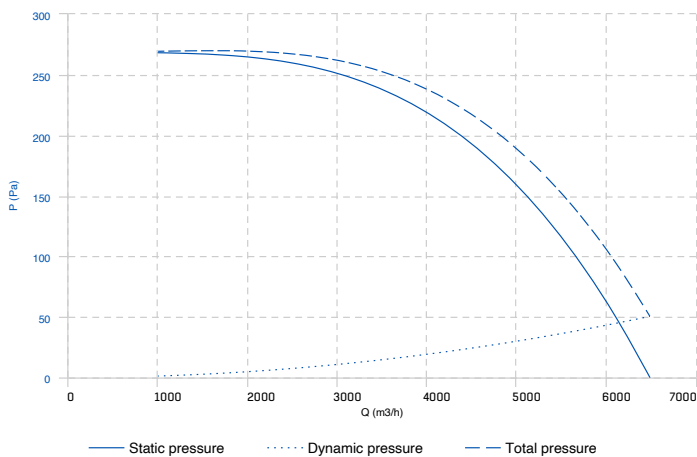

Model Name	Part Code	Motor Nominal data at 50Hz supply voltage	Power (kW)	Max Current (A)	Max. Airflow (m³/h)	Speed (rpm)	IP Class
HTC-500-6-3-0.75	CH500635	380-420V/50Hz/3pH	0.75	1.95	6490	910	IP55

Model Name	Sound Path	Lw Spectrum [dB(A)]								
		63	125	250	500	1000	2000	4000	8000	Total
HTC-500-6-3-0.75	Inlet	57	65	70	73	74	72	69	64	79

Fan Size	A	B	C	D	E	F	G	H	I	K	Weight (kg)
HTC-500-6-3-0.75	939.6	863.65	939	710	9	353	319.5	50	31	463.15	50

DRAWINGS AND DIMENSIONS

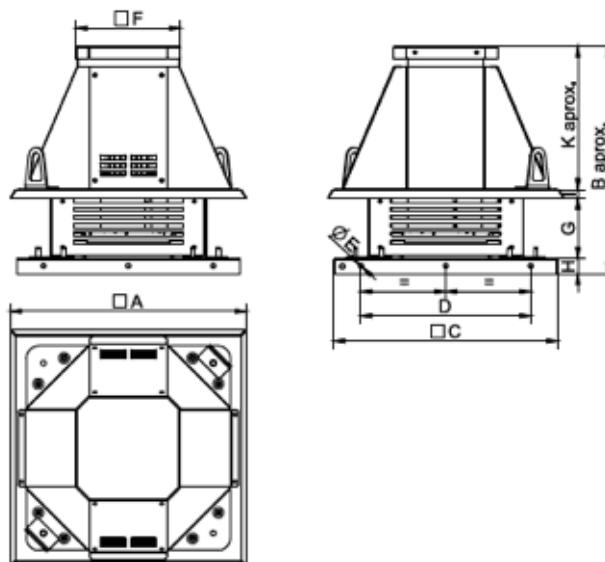

INVERTER DETAILS

Part Number	Description
EA901016	IDDXF-54-2.2



PERFORMANCE CHART

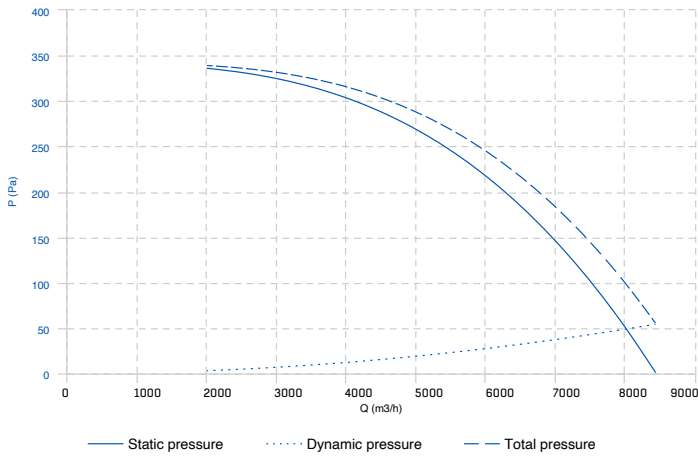

Model Name	Part Code	Motor Nominal data at 50Hz supply voltage	Power (kW)	Max Current (A)	Max. Airflow (m³/h)	Speed (rpm)	IP Class
HTC-560-6-3-0.75	CH560635	380-420V/50Hz/3pH	0.75	1.95	8430	910	IP55

Model Name	Sound Path	Lw Spectrum [dB(A)]								
		63	125	250	500	1000	2000	4000	8000	Total
HTC-560-6-3-0.75	Inlet	60	68	72	76	77	75	72	67	82

Fan Size	A	B	C	D	E	F	G	H	I	K	Weight (kg)
HTC-560-6-3-0.75	939.6	880.65	939	710	9	353	336.5	50	31	463.15	55

DRAWINGS AND DIMENSIONS

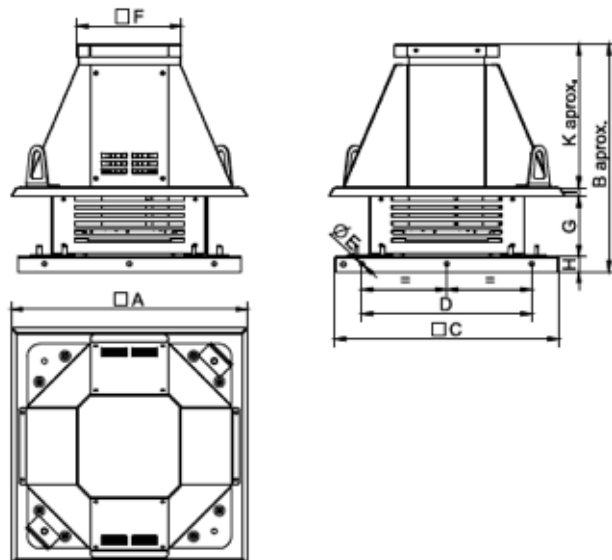

INVERTER DETAILS

Part Number	Description
EA901016	IDDXF-54-2.2



HTC-630-6-3-1.5

PERFORMANCE CHART

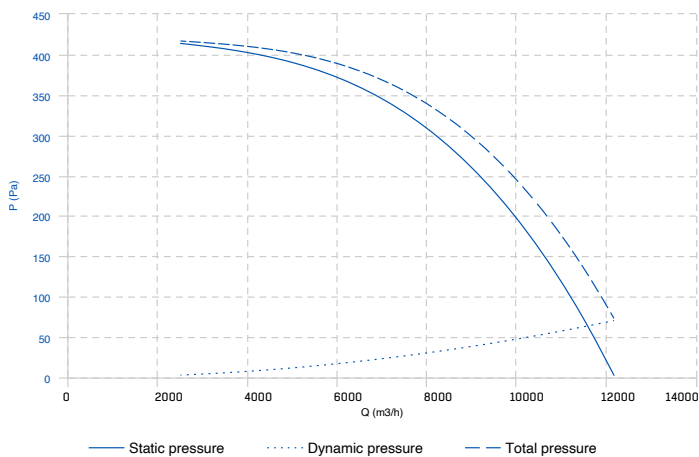

Model Name	Part Code	Motor Nominal data at 50Hz supply voltage	Power (kW)	Max Current (A)	Max. Airflow (m³/h)	Speed (rpm)	IP Class
HTC-630-6-3-1.5	CH630635	380-420V/50Hz/3pH	1.5	3.71	12170	940	IP55

Model Name	Sound Path	Lw Spectrum [dB(A)]								
		63	125	250	500	1000	2000	4000	8000	Total
HTC-630-6-3-1.5	Inlet	63	71	76	79	80	79	75	70	86

Fan Size	A	B	C	D	E	F	G	H	I	K	Weight (kg)
HTC-630-6-3-1.5	939.6	922.65	939	710	9	353	378.5	50	31	463.15	70

DRAWINGS AND DIMENSIONS

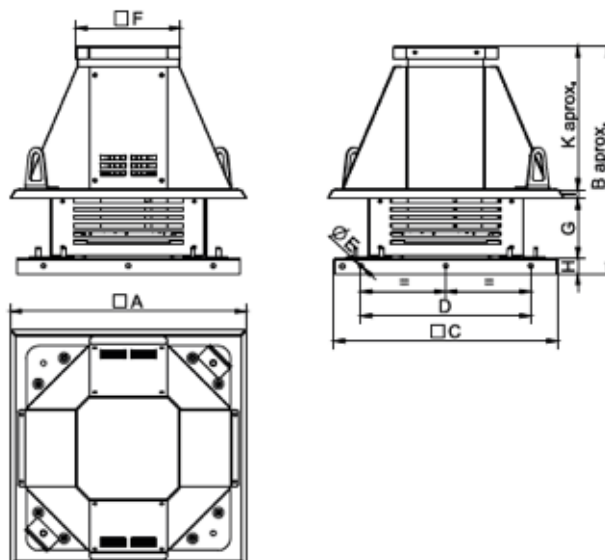

INVERTER DETAILS

Part Number	Description
EA901018	IDDXF-54-5.3



PERFORMANCE CHART

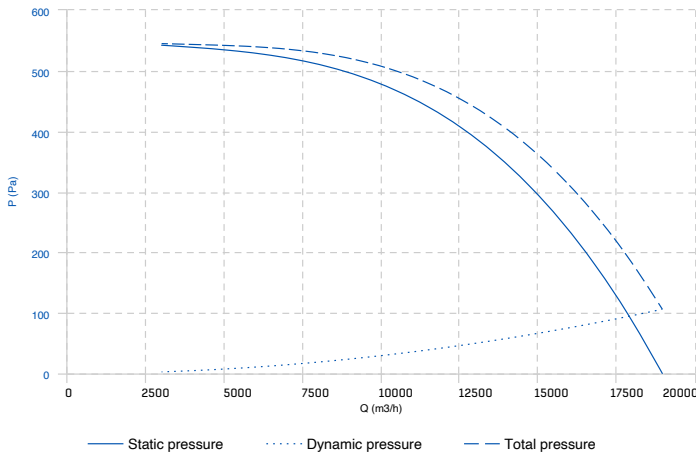

Model Name	Part Code	Motor Nominal data at 50Hz supply voltage	Power (kW)	Max Current (A)	Max. Airflow (m³/h)	Speed (rpm)	IP Class
HTC-710-6-3-2.2	CH710635	380-420V/50Hz/3pH	2.2	5.94	18980	940	IP55

Model Name	Sound Path	Lw Spectrum [dB(A)]								
		63	125	250	500	1000	2000	4000	8000	Total
HTC-710-6-3-2.2	Inlet	68	76	80	84	85	83	80	75	90

Fan Size	A	B	C	D	E	F	G	H	I	K	Weight (kg)
HTC-710-6-3-2.2	1134.6	1116.22	1035	840	9	453	441.5	50	31	593.72	170

DRAWINGS AND DIMENSIONS

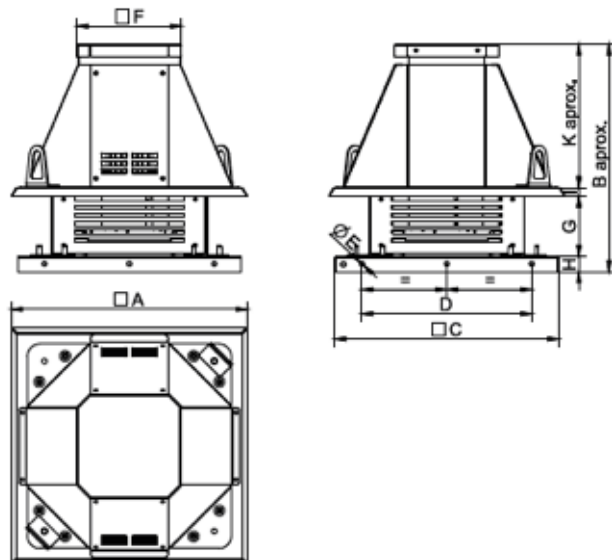

INVERTER DETAILS

Part Number	Description
EA901019	IDDXF-54-7.2



HTC-800-6-3-4

PERFORMANCE CHART

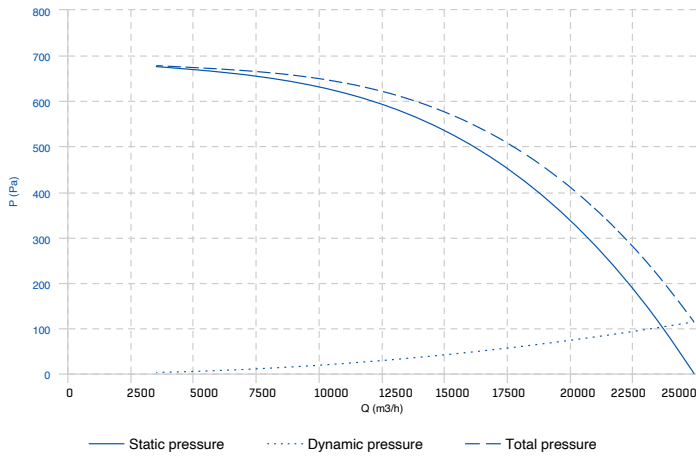

Model Name	Part Code	Motor Nominal data at 50Hz supply voltage	Power (kW)	Max Current (A)	Max. Airflow (m³/h)	Speed (rpm)	IP Class
HTC-800-6-3-4	CH800635	380-420V/50Hz/3pH	4.0	9.46	24950	960	IP55

Model Name	Sound Path	Lw Spectrum [dB(A)]								
		63	125	250	500	1000	2000	4000	8000	Total
HTC-800-6-3-4	Inlet	71	79	83	86	88	86	83	77	93

Fan Size	A	B	C	D	E	F	G	H	I	K	Weight (kg)
HTC-800-6-3-4	1134.6	1142.72	1035	840	9	453	468	50	31	593.72	205

DRAWINGS AND DIMENSIONS

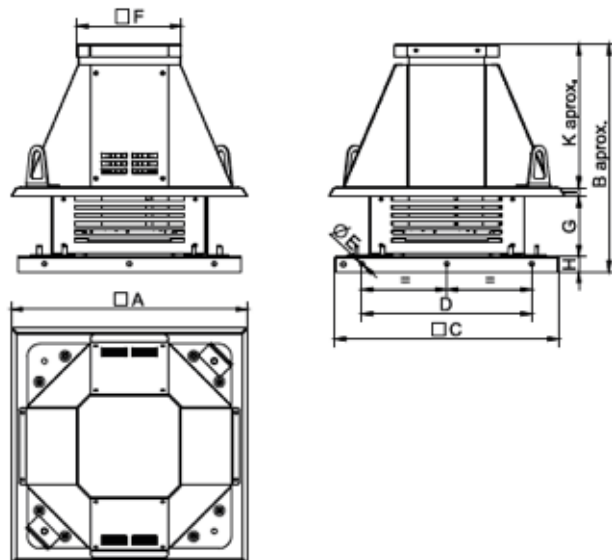

INVERTER DETAILS

Part Number	Description
EA901021	IDDXF-54-12



PERFORMANCE CHART

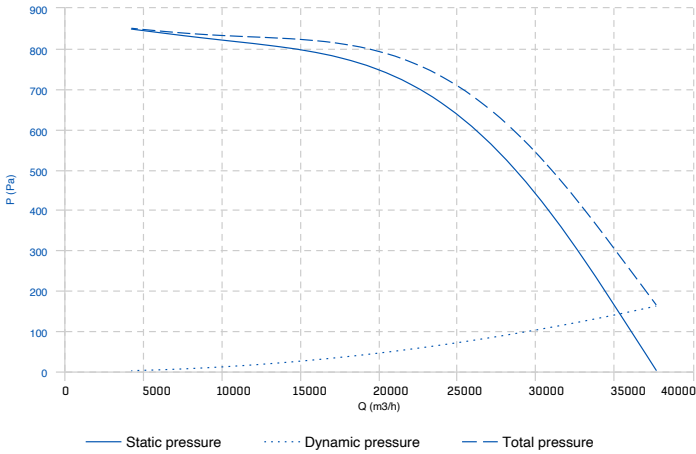

Model Name	Part Code	Motor Nominal data at 50Hz supply voltage	Power (kW)	Max Current (A)	Max. Airflow (m³/h)	Speed (rpm)	IP Class
HTC-900-6-3-11	CH900635	380-420V/50Hz/3pH	11.0	22.6	37650	965	IP55

Model Name	Sound Path	Lw Spectrum [dB(A)]								
		63	125	250	500	1000	2000	4000	8000	Total
HTC-900-6-3-11	Inlet	89	87	84	82	80	77	74	71	93

Fan Size	A	B	C	D	E	F	G	H	I	K	Weight
HTC-900-6-3-11	1412	1366	1365	1210	20	453	541	50	41.5	733	250

DRAWINGS AND DIMENSIONS

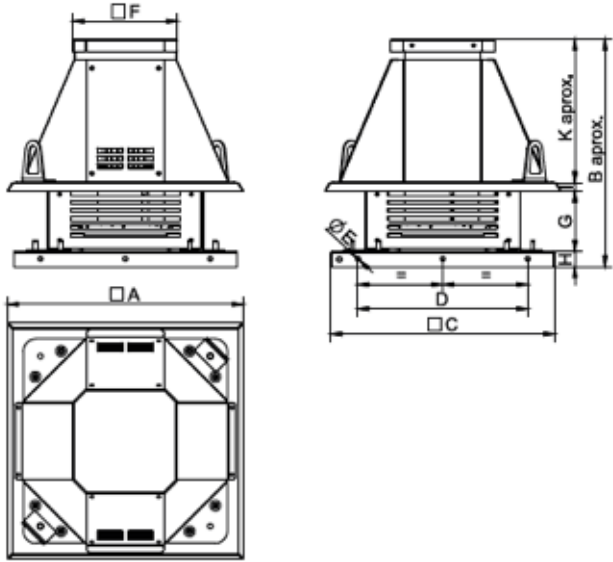

INVERTER DETAILS

Part Number	Description
EA901023	IDDXF-54-23



PERFORMANCE CHART

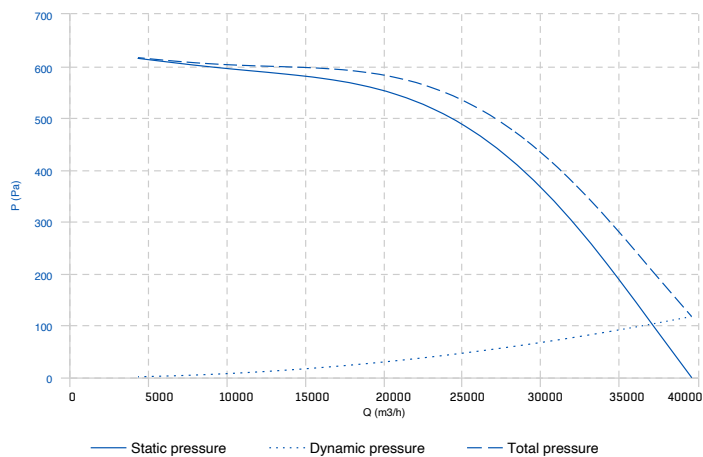

Model Name	Part Code	Motor Nominal data at 50Hz supply voltage	Power (kW)	Max Current (A)	Max. Airflow (m³/h)	Speed (rpm)	IP Class
HTC-1000-8-3-7.5	CH100835	380-420V/50Hz/3pH	7.5	17.0	39600	725	IP55

Model Name	Sound Path	Lw Spectrum [dB(A)]								
		63	125	250	500	1000	2000	4000	8000	Total
HTC-1000-8-3-7.5	Inlet	87	85	82	80	78	75	72	69	91

Fan Size	A	B	C	D	E	F	G	H	I	K	Weight
HTC-1000-8-3-7.5	1412	1436	1365	1210	20	453	611.5	50	41.5	733	411

DRAWINGS AND DIMENSIONS

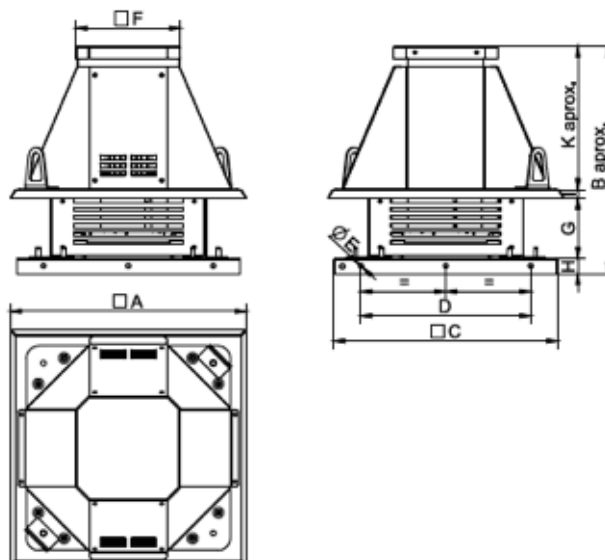

INVERTER DETAILS

Part Number	Description
EA901023	IDDXF-54-23



1 PHASE

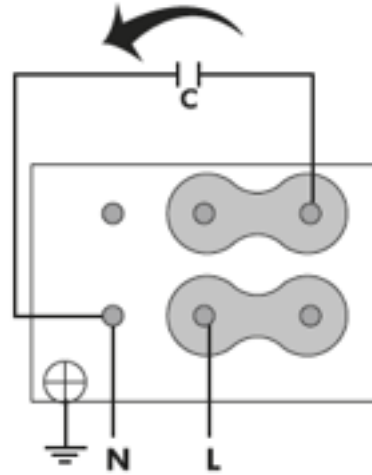
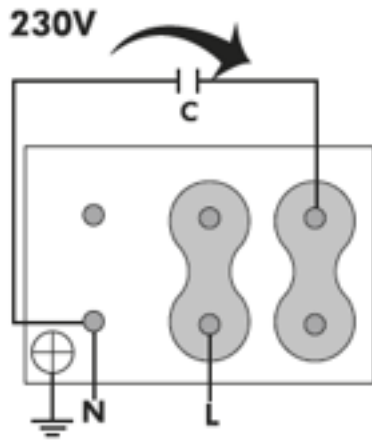

3 PHASE

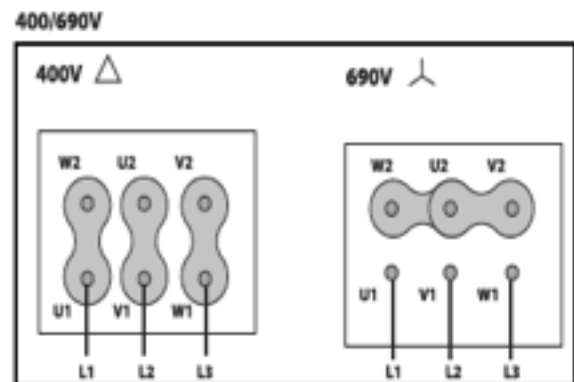
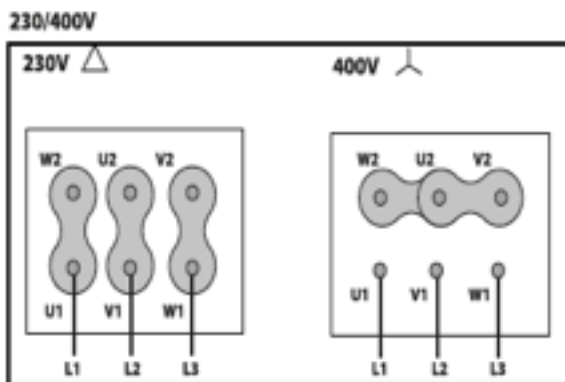

DAMPER



Description

This is an overpressure damper used to maintain pressure or depression within a room from the outside or other adjacent room. The frame is made of galvanized steel. Pressure drop: 50 Pa.

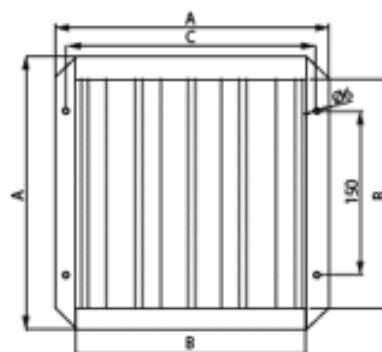

Size	Part Number	Φ	A (mm)	B (mm)	C (mm)	Nb	h	N° slots
250/280/315	CS025000	6	250	210	234	2	75	4
355/400/450	CS035500	6	350	310	334	3	75	6
500/560/630	CS050000	8	484	444	468	3	75	9
710/800	CS071000	8	796	756	780	3	75	13

SWING-OUT FRAME

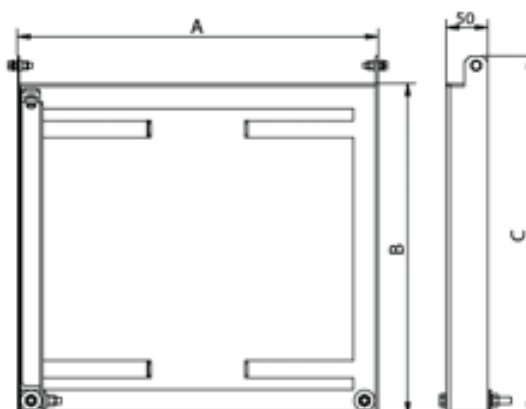

Size	Part Number	A (mm)	B (mm)	C (mm)
225/250	KB022500	433	397	430
280/315	KB028000	553	517	550
355/400	KB035500	623	587	620
700	KB045000	703	667	700
500/560/630	KB050000	898	862	895
710/800	KB071000	1093	1057	1090

VERTICAL DISCHARGE SOCKET

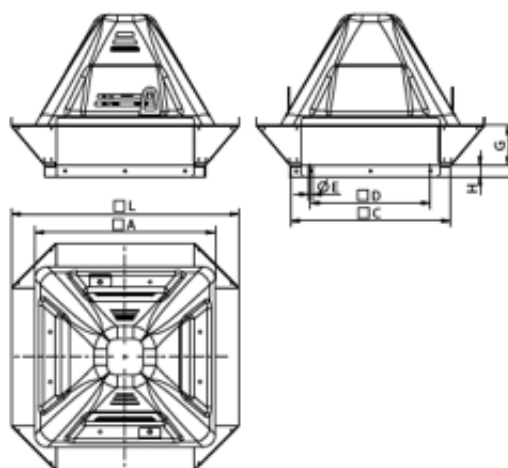

Size	Part Number	A (mm)	C (mm)	D (mm)	E (mm)	G (mm)	H (mm)	L (mm)
225/250	KV022500	496	440	330	12	110	30	626.6
280/315	KV028000	616	560	450	12	180	40	770
355/400	KV035500	698.5	630	535	12	260	40	932.2
450	KV045000	777	710	590	14	30	40	1059.4
500/560/630	KV050000	972.75	905	750	14	375	50	1341
710/800	KV071000	1168.5	1100	940	14	460	59	1634.2

BASE FOR SLOPING ROOF (5-45°)

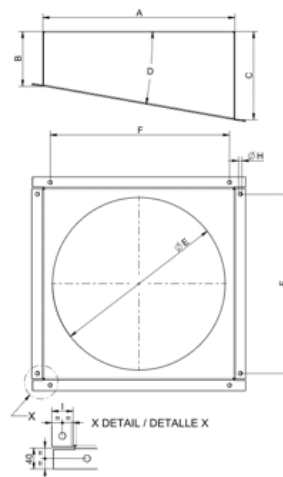

Size	Part Number	A (mm)	B (mm)	C (mm)	D (mm)	E (mm)	F (mm)	I (mm)
250	FS042000	420	150	X	xx°	250	380	40
315	FS048500	485	150	X	xx°	300	445	40
400	FS053500	535	150	X	xx°	400	495	40
450	FS058000	580	150	X	xx°	450	540	40
500	FS063500	635	150	X	xx°	450	595	40
560	FS071500	715	150	X	xx°	450	675	40
630	FS081500	815	200	X	xx°	630	775	40
710	FS090500	905	200	X	xx°	710	865	40
800	FS010500	1005	200	X	xx°	800	965	40

Note: xx° -> The degree of inclination X -> The length of C depending on xx°